

Fluid:	Blast Furnace Gas
Industry:	Steel
Application:	Pitot traverse 50" and 77"
Specifications:	Calibration of Verabar to verify accuracy

Application

Blast furnace gas to utility and flare

Pressure/Temp: 5 PSI/100°F
Flow Rate: 25,000 to 250,000 SCFM
Pipe Sizes: 50", 77"
Focus: 50" Flare

Problem

Internal structural supports of the existing flare stack created a non-standard flow profile. The "L" shaped circular brackets protruded into the flow stream five (5) inches causing an eddy region at the Verabar's installation.

Solutions

- **Easy and Adaptable Installation:** Sensors custom made per customer requirements; hand insertable for easy removal/inspection
- **High Accuracy:** Mathematically verified flow coefficients and multiple sensing ports spanning the large diameter ducts
- **Field Service/Engineering:** Veris Engineers performed in-line calibration and data reduction to verify Verabar flow coefficients and accuracy required for custody transfer (utility) and flare (EPA) measurement

Veris performed an on-site pitot traverse at the Verabar locations in two planes 80 feet high on the customer's flare stack. The data produced from the traverse was normalized and reduced to create a customized flow coefficient representing the actual flowing conditions.

Results

A true representation of the flow profile provided the necessary documentation, accuracy and error analysis for the customer's billing requirements.

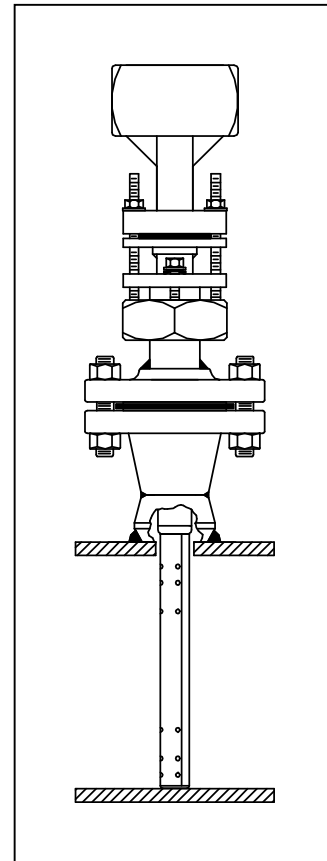

Verabar Model V550



Verabar Model V550 Installed